

Material Management

Elke Kaffka
Eberhard Thurow

Energiewerke Nord
GmbH



1.800.000 Mg



Finding out:

- **contaminated and not contaminated areas**
- **different contamination levels**
- **nuclide vectors**



- **Category I - unrestricted material**
- **Category II - suspected material**
- **Category III - contaminated material**



Categorisation of plant masses

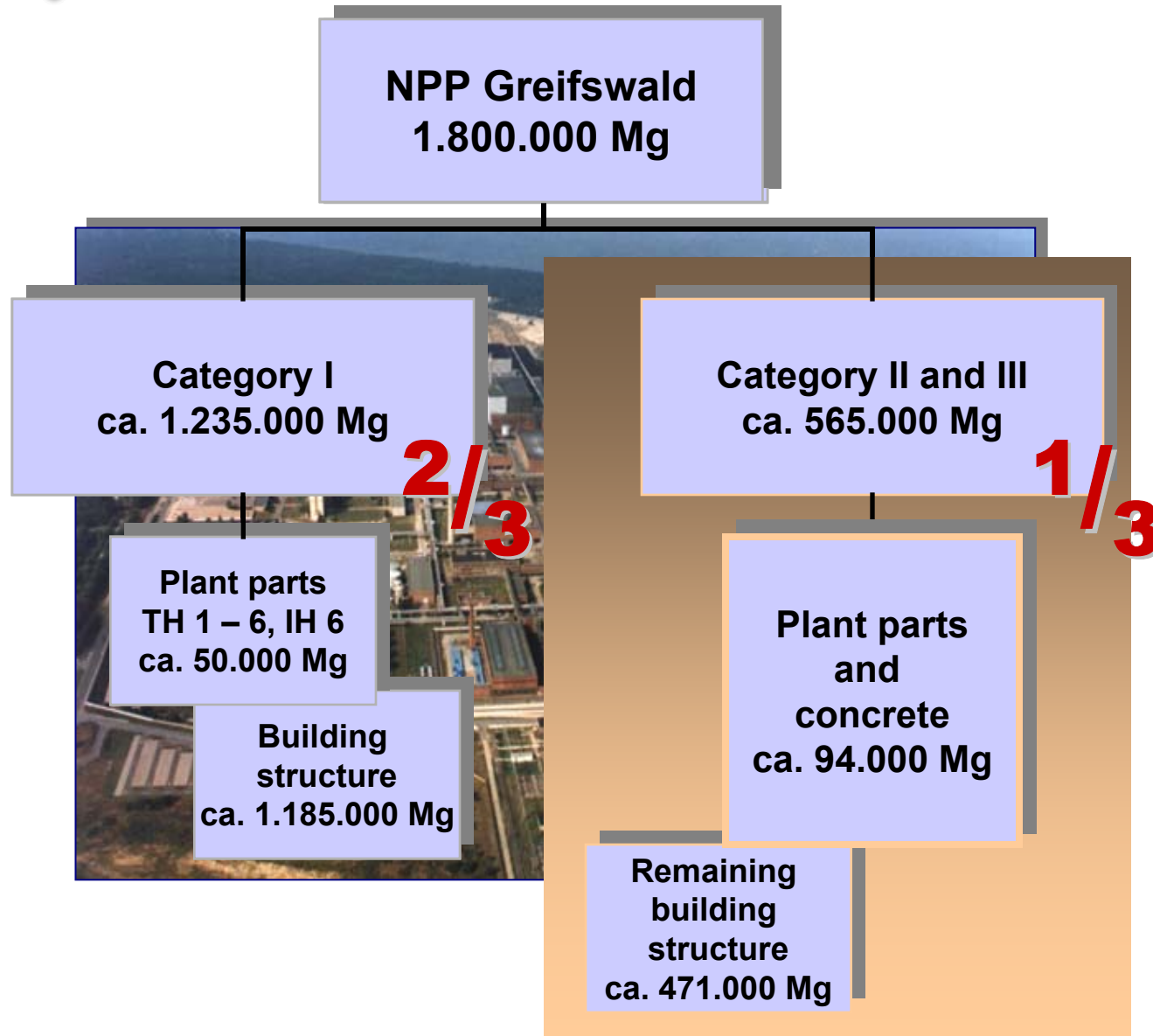



Mass flow category I

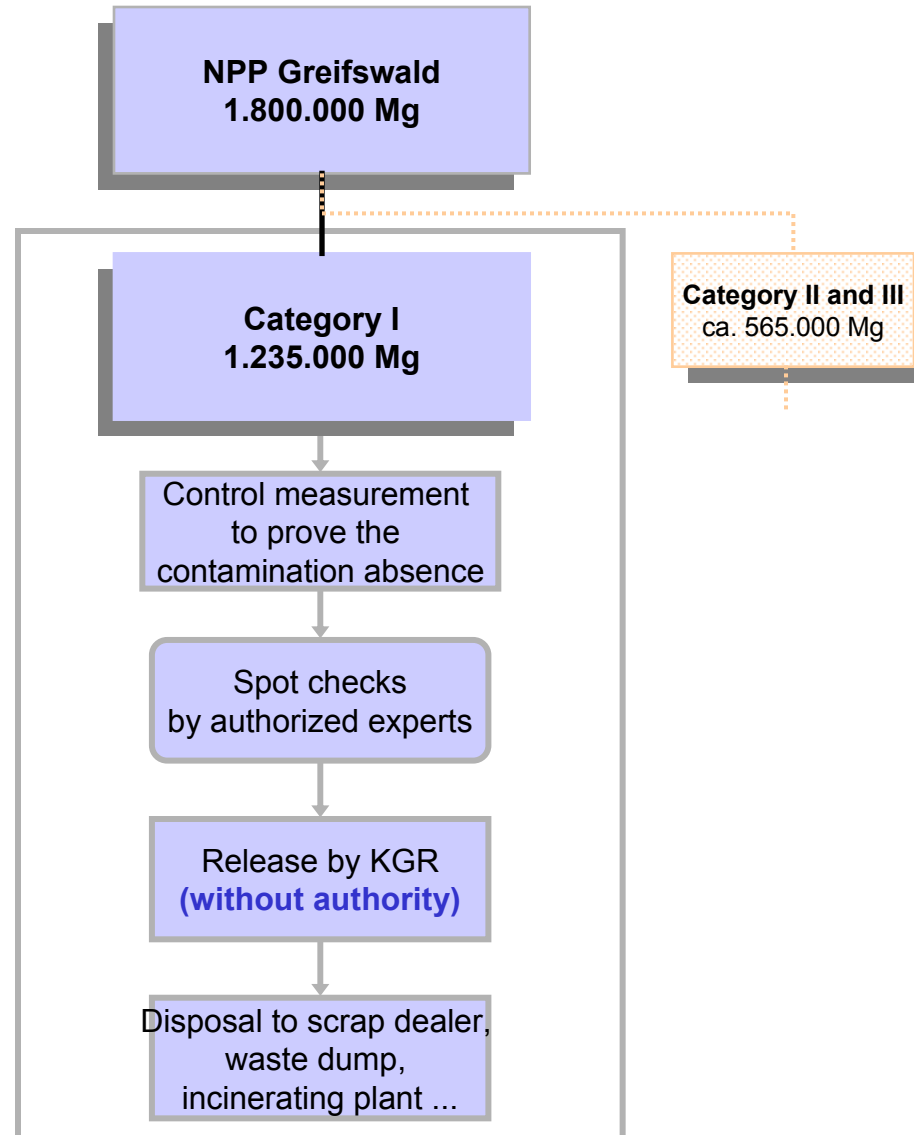



Mass flow category II and III

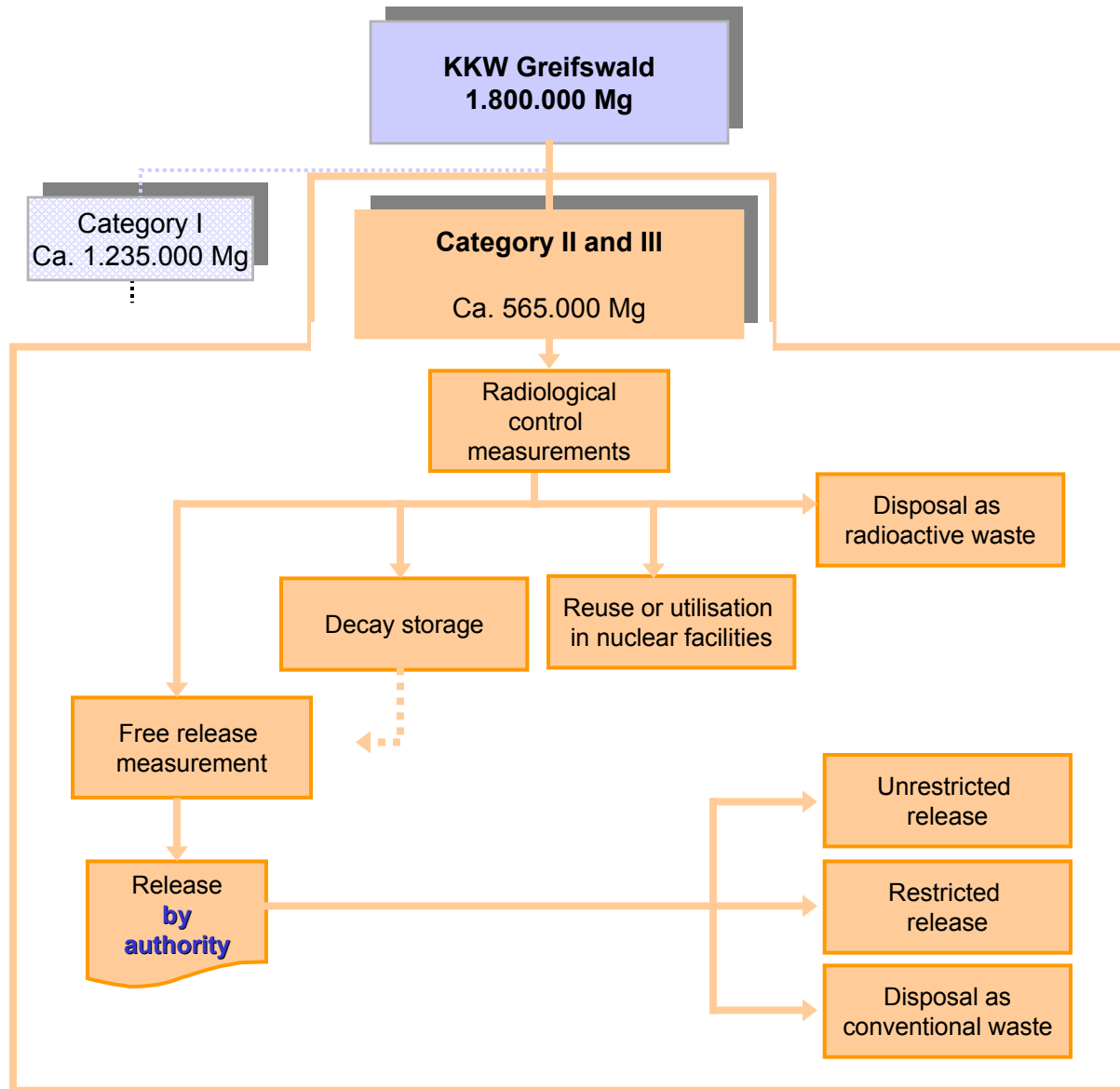



Disposal goals

- **A Unrestricted release**
- **B Restricted release**
- **C Disposal as conventional waste**
- **D Decay storage**
- **E Reuse or Utilisation in nuclear facilities**
- **F Disposal as radioactive waste**





Masses and disposal goals

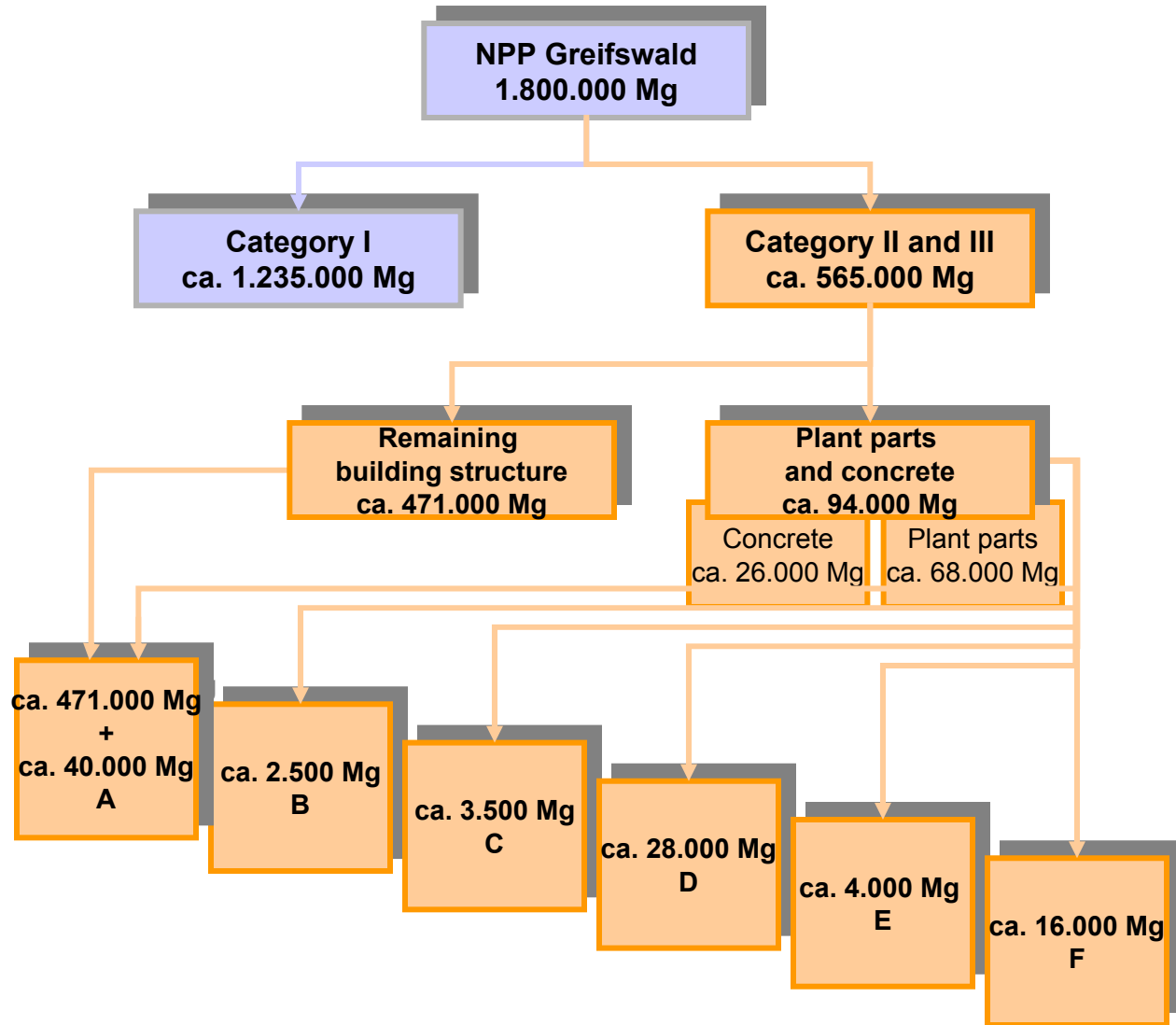



Comparison plan and actual

Disposal goal	Dismantled material	
	Plan	Actual status
A	89.1%	44.2%
B	0.5%	33.0%
C	0.7%	8.4%
D	5.6%	13.3% (13,0% Big components)
E	0.8%	0.5%
F	3.2%	0.8% (only disposal in Final storage)





Practice - Category II +III

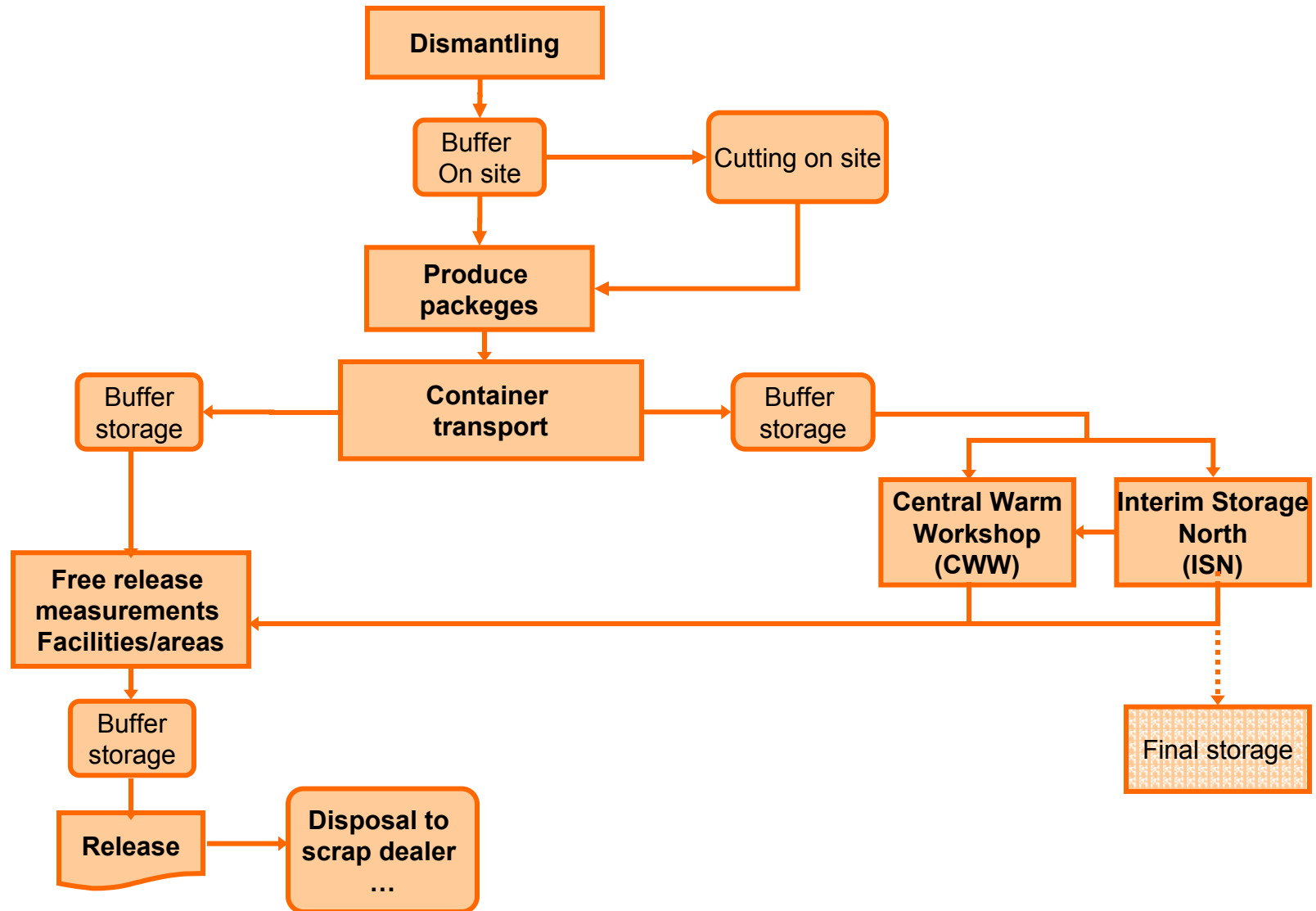



- Carbon steel CST
- Stainless steel SST
- Electric motors ELM
- Cable CAB
- Insulation wool ISW
- Non-ferrous metals NFM
- Electrical parts ELP
- Concrete CON
- Other material OTH
- Components COM





Dismantled material

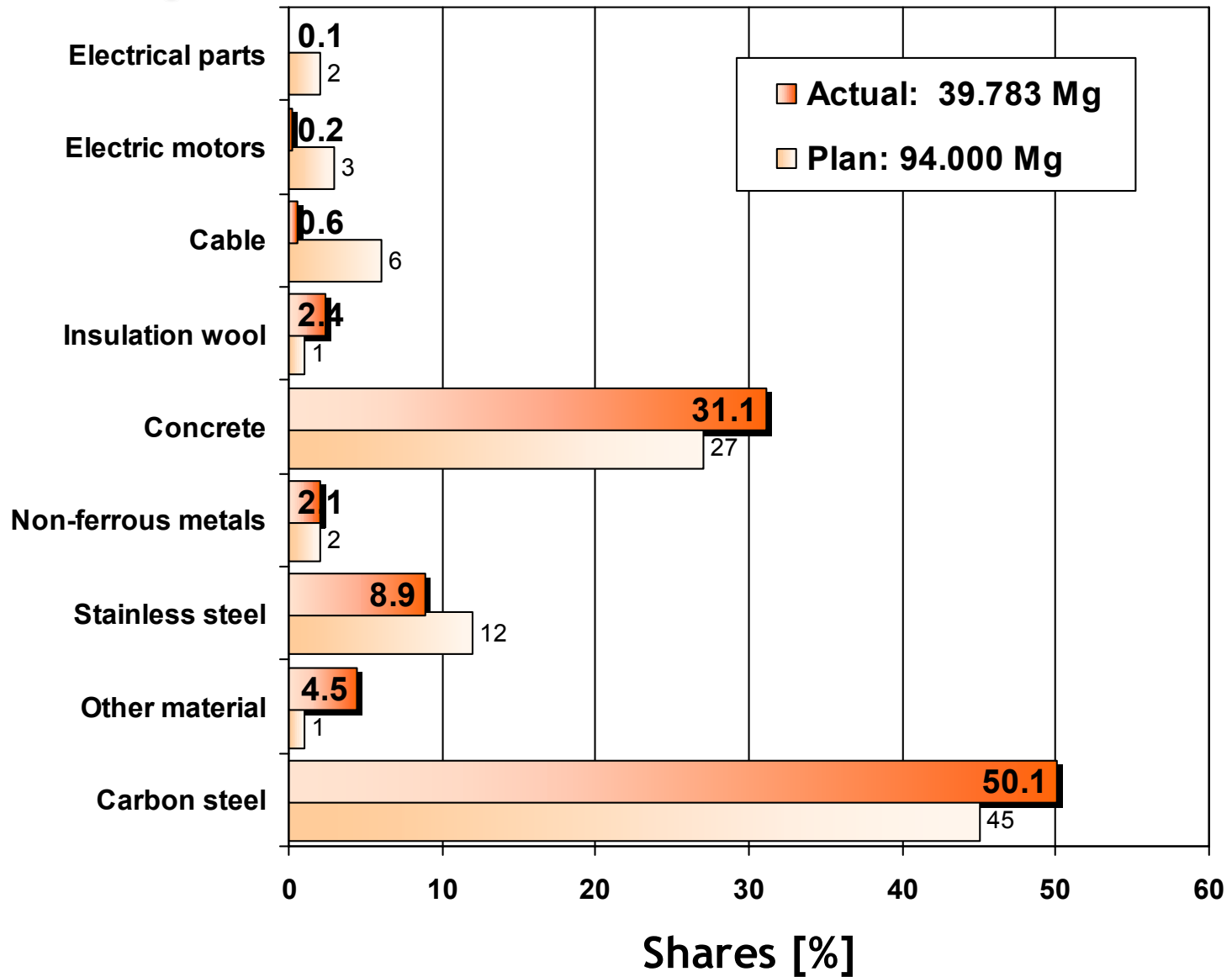



Waste flow management

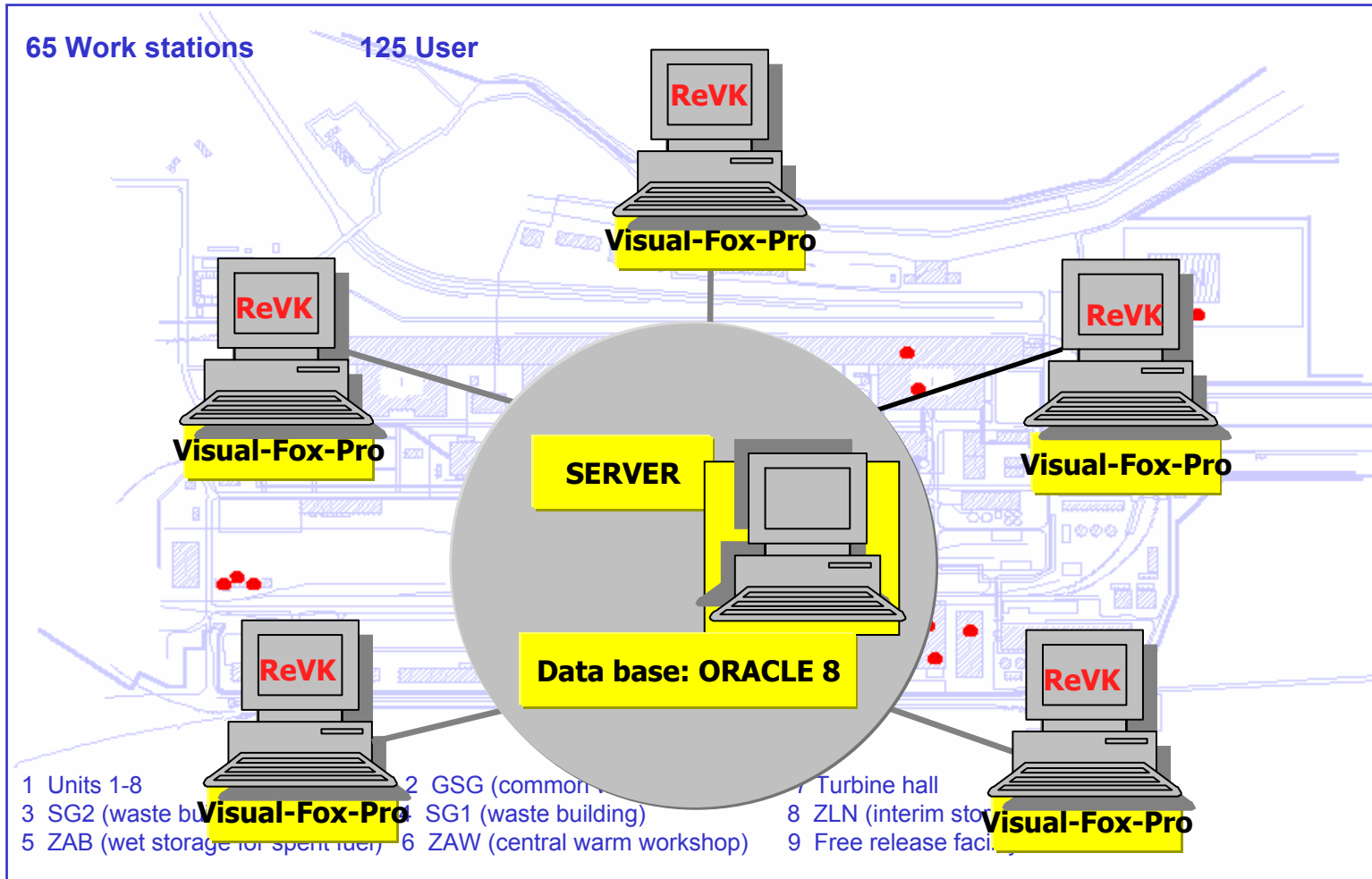

EUNDETRAF



Thanks for your attention...

Types of material – 2. Level



- Carbon steel CST
- Stainless steel SST
- Electric motors ELM
- Cable CAB
- Insulation wool ISW
- Non-ferrous metals NFM
- Electrical parts ELP
- Concrete CON
- Other material OTH
- Components COM

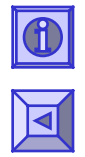
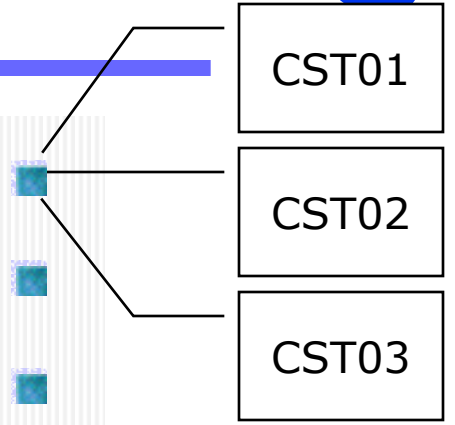



- Carbon steel
- Stainless steel
- Electric motors
- Cable
- Insulation wool
- Non-ferrous metals
- Electrical parts
- Concrete
- Other material
- Components

CST
SST
ELM
CAB
ISW
NFM
ELP
CON
OTH
COM

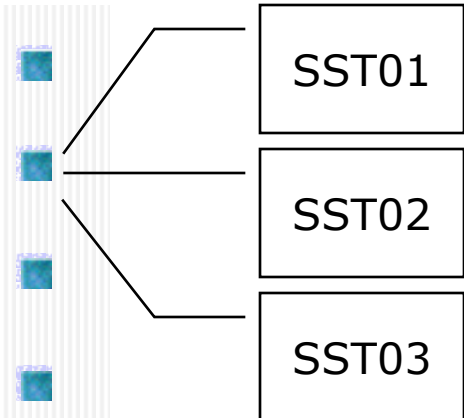



Material types – Overview

		Description
CST	CST01	Wall thickness > 30 mm
	CST02	Wall thickness 10 – 30 mm
	CST03	Wall thickness < 10 mm
SST	SST01	Wall thickness > 30 mm
	SST02	Wall thickness 7 – 30 mm
	SST03	Wall thickness < 7 mm
ELM	ELM01	Biggest diameter < 400 mm
	ELM02	Biggest diameter > 400 mm
CAB	CAB00	Insulation of the cable (e. g. plastic, rubbers)
	CAB01	Biggest diameter < 25 mm
	CAB02	Biggest diameter >25 mm
ISW	ISW00	-
NFM	NFM01	The metal could be melted
	NFM02	The metal couldn't be melted
ELP	ELP00	-
CON	CON00	-
OTH	OTH00	-



Kinds of packages



Box



Drum



20' Container



Skip container



Concrete container



Components



Buffer places

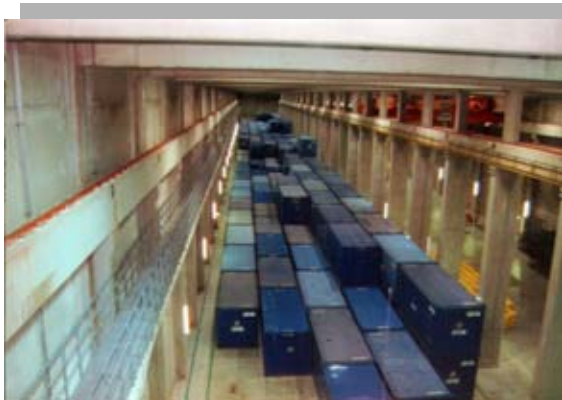



Reception requirements

- Surface contamination outside of packages $<0.5 \text{ Bq/cm}^2$
- Dose rate outside of package $<1.0 \text{ } \mu\text{Sv/h}$
(measure distance 10 cm)





Re



Interim Storage North



Dismantling in the turbine hall





Limit values

A1	<p>Unrestricted release of metals for unrestricted use or utilisation: 0.1 Bq/g total activity and contamination according to annex IX , column 4 of Radiation Protection Ordinance, max. 10 000 t/a</p>
A2	<p>Release of other residual material: 0.2 Bq/g Co-60-equivalent activity or existence of a defined surface and contamination according to annex IX, column 4 of Radiation Protection Ordinance, max. 100 t/week</p>
A3	<p>Release of buildings for general unrestricted use: 0.015 Bq/cm² or alternatively 0.005 Bq/g Co-60-equivalent activity in the topmost centimetre</p>
B1	<p>Release of scrap for melting: 1.0 Bq/g total activity and contamination according to annex IX, column 4 of Radiation Protection Ordinance, max. 10 000 t/a</p>
B2	<p>Release of debris from building demolition for utilisation: 0.2 Bq/g Co-60-equivalent activity, max. 100 t/week</p>
B3	<p>Release of buildings for demolition: 0.5 Bq/cm² Co-60-equivalent activity or 0.2 Bq/g Co-60-equivalent activity in the topmost centimetre</p>
C	<p>Release of residual material for deposition as conventional waste: summary of nuclide specific indices according to the recommendation of the Federal Ministry for Environment for the application of the recommendation draft of the Radiation Protection Commission, e.g. Co-60 2 Bq/g, max. 100t/a</p>

